



# Side Dump

Thurston Manufacturing Company

Featuring the Exclusive  
**FLX-500 Dump Body**  
2-Year Warranty

## Tri-Axle



**Easier, faster unload**...stockpile, dump in tight spaces or windrow the load. Circle R Side Dumps unload from either side.

**Higher capacity level full**...Largest standard payload...24.2 yd<sup>3</sup>

**Superior handling**...because even large loads fit into a low-profile Circle R Side Dump

- ▶ Left side latch handle also controls opposite latch, one side opens as other side closes
- ▶ Rubber "EdgeFlex" Fenders will take maximum abuse with bolt-on brackets
- ▶ "FlexCorner" tub design for tough off road conditions
- ▶ Larger single "G-Rail"...lighter weight and stronger than two rail systems...puts extra strength at the dump edge
- ▶ Six integrated tub pivot points reduce trailer and tub flex
- ▶ Greaseless pivot bearings reduce pin wear, provides longer life...low maintenance



**Thurston Manufacturing Company**  
1708 H Avenue • P.O. Box 218  
Thurston, Nebraska • 68062-0218  
Phone: 402-385-3041 • Fax: 402-385-3043  
[www.thurstonmfgco.com](http://www.thurstonmfgco.com)  
Form No. 10CRTri-Axle-0810TM

**See Your Circle R Dealer  
or Call our  
Circle R Hotline  
Today....800-633-1648**



# Side Dump

Thurston Manufacturing Company

# Tri-Axle

### Tri-Axle Trailer Specifications and Features

- 20" Deep Twin "I" Beam Chassis with 3/8" Fifth Wheel Plate
- Tub dump direction indicators visible in truck mirrors
- Holland 51000 Landing Gear w/ 2 Speed Gear Box
- Meritor 25,000 lb Round Axles w/ 5/8" Wall Tubing
- Haldex 2S1M ABS System
- Six Integrated Tub Pivot Points with Greaseless Pivot Bearings.
- Tub dump direction controlled from two places on the left side. No need to walk all around the trailer to change dump direction.
- Rubber "EdgeFlex" fenders with bolt-on mounts. Easily replace damaged fender parts.
- 1/4" FLX-500 Tub with Exclusive "Flex Corner" Design. (1/4" AR400 Available)
- Large Single "G" Rail on Tub. Lighter and Stronger than two rail systems.
- Suspensions: Hutchens Cast 9700 Leaf Spring or Neway RL-230 Air Ride. Neway RL-250 on Lifiable Axles
- Front or Rear Lift Axle Option on Most Models
- Wheel & Tire Options: 11R22.5 or 11R24.5 on Steel or Aluminum Rim, 385/65R22.5 on Aluminum Rim  
New or Recap Tires Available. Other sizes available upon request.
- Hydraulic System: 3000 psi rated 3/4" Hoses, Fittings, Flow Divider, and Relief Valve. Trailer Mounted Electric Over Hydraulic Control Valve Available.
- Twin 3000 psi rated 5" Cylinders (Optional 6" Cylinders Available)
- Standard LED lights in enclosed boxes with sealed plugs.
- Bolt-on Push/Lift block with Under Ride Bumper conform to Federal Motor Vehicle Safety Standards.
- Standard Colors: Black, White, Yellow, and Burgundy. Custom Colors Available.
- Optional Roll Rite Electric Tarp.

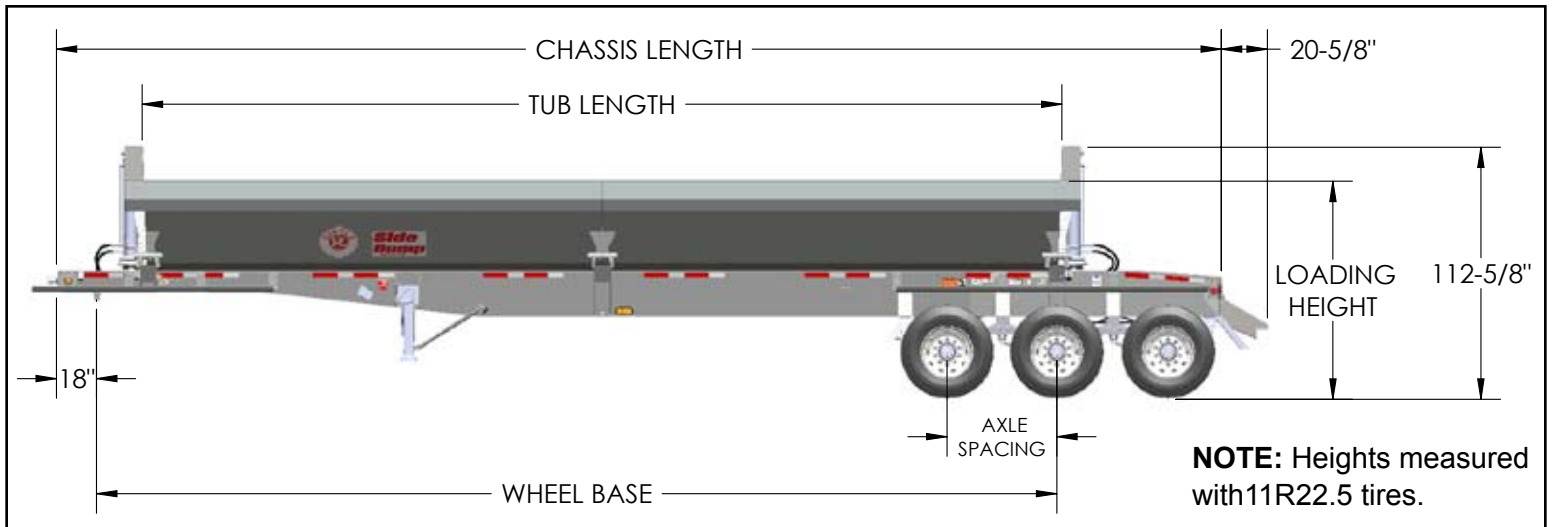
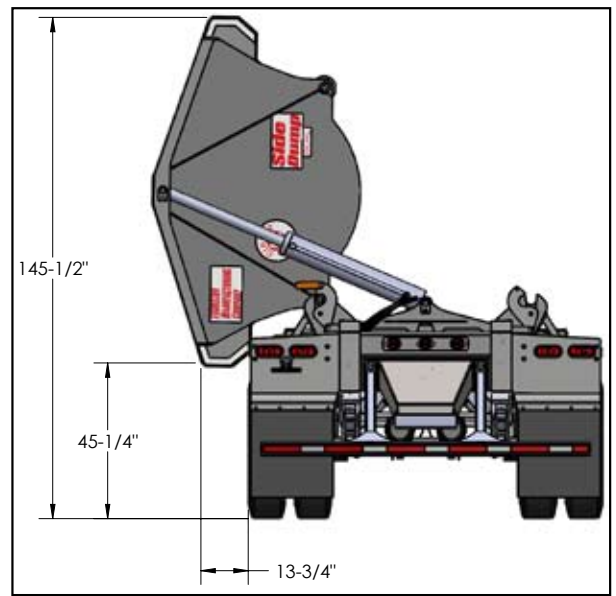

Model	Suspension	Chassis Length	Wheel Base	Axle Spacing	Tub Length	Tub Volume	Loading Height
35' Tri-Axle	Leaf Spring	35'-4"	333"	49"	30'-3"	21.4 Cu Yd	97-1/2"
	Air Ride	35'-4"	324.5"	49"	30'-3"	21.4 Cu Yd	97-1/2"
40' Tri-Axle	Leaf Spring	39'-4"	381"	49"	34'-3"	24.2 Cu Yd	97-1/2"
	Air Ride	40'-5"	383"	49"	34'-3"	24.2 Cu Yd	97-1/2"
42' Tri-Axle	Leaf Spring	41'-4"	404"	49"	34'-3"	24.2 Cu Yd	97-1/2"
	Air Ride	42'-1"	404"	49"	34'-3"	24.2 Cu Yd	97-1/2"
44' Tri-Axle	Leaf Spring	43'-5"	429"	49"	34'-3"	24.2 Cu Yd	97-1/2"
	Air Ride	44'-2"	428"	49"	34'-3"	24.2 Cu Yd	97-1/2"
	Spread Air Ride	44'-2"	417"	60"	34'-3"	24.2 Cu Yd	97-1/2"