



Side Dump

Thurston Manufacturing Company

Featuring the Exclusive
FLX-500 Dump Body
2-Year Warranty

Tandem-Axle



Easier, faster unload...stockpile, dump in tight spaces or windrow the load. Circle R Side Dumps unload from either side.

Higher capacity level full...Largest standard payload...24.2 yd³

Superior handling...because even large loads fit into a low-profile Circle R Side Dump

- ▶ Left side latch handle also controls opposite latch, one side opens as other side closes
- ▶ Rubber "EdgeFlex" Fenders will take maximum abuse with bolt-on brackets
- ▶ "FlexCorner" tub design for tough off road conditions
- ▶ Larger single "G-Rail"...lighter weight and stronger than two rail systems...puts extra strength at the dump edge
- ▶ Six integrated tub pivot points reduce trailer and tub flex
- ▶ Greaseless pivot bearings reduce pin wear, provides longer life...low maintenance



Thurston Manufacturing Company

1708 H Avenue • P.O. Box 218

Thurston, Nebraska • 68062-0218

Phone: 402-385-3041 • Fax: 402-385-3043

www.thurstonmfgco.com

Form No. 10CRTandem-Axle-0810TM

**See Your Circle R Dealer
or Call our
Circle R Hotline
Today....800-633-1648**



Side Dump

Thurston Manufacturing Company

Tandem-Axle

Tandem Axle Trailer Specifications and Features

- 20" Deep Twin "I" Beam Chassis with 3/8" Fifth Wheel Plate
- Tub dump direction indicators visible in truck mirrors
- Holland 51000 Landing Gear w/ 2 Speed Gear Box
- Meritor 25,000 lb Round Axles w/ 5/8" Wall Tubing
- Haldex 2S1M ABS System
- Six Integrated Tub Pivot Points with Greaseless Pivot Bearings.
- Tub dump direction controlled from two places on the left side. No need to walk all around the trailer to change dump direction.
- Rubber "EdgeFlex" fenders with bolt-on mounts. Easily replace damaged fender parts.
- 1/4" FLX-500 Tub with Exclusive "Flex Corner" Design. (1/4" AR400 Available)
- Large Single "G" Rail on Tub. Lighter and Stronger than two rail systems.
- Suspensions: Hutchens Cast 9700 Leaf Spring, Hutchens Single Point, or Neway RL-230 Air Ride.
- Wheel & Tire Options: 11R22.5 or 11R24.5 on Steel or Aluminum Rim, 385/65R22.5 on Aluminum Rim
New or Recap Tires Available. Other sizes available upon request.
- Hydraulic System: 3000 psi rated 3/4" Hoses, Fittings, Flow Divider, and Relief Valve. Trailer Mounted Electric Over Hydraulic Control Valve Available.
- Twin 3000 psi rated 5" Cylinders (Optional 6" Cylinders Available)
- Standard LED lights in enclosed boxes with sealed plugs.
- Bolt-on Push/Lift block with Under Ride Bumper conform to Federal Motor Vehicle Safety Standards.
- Standard Colors: Black, White, Yellow, and Burgundy. Custom Colors Available.
- Optional Roll Rite Electric Tarp.

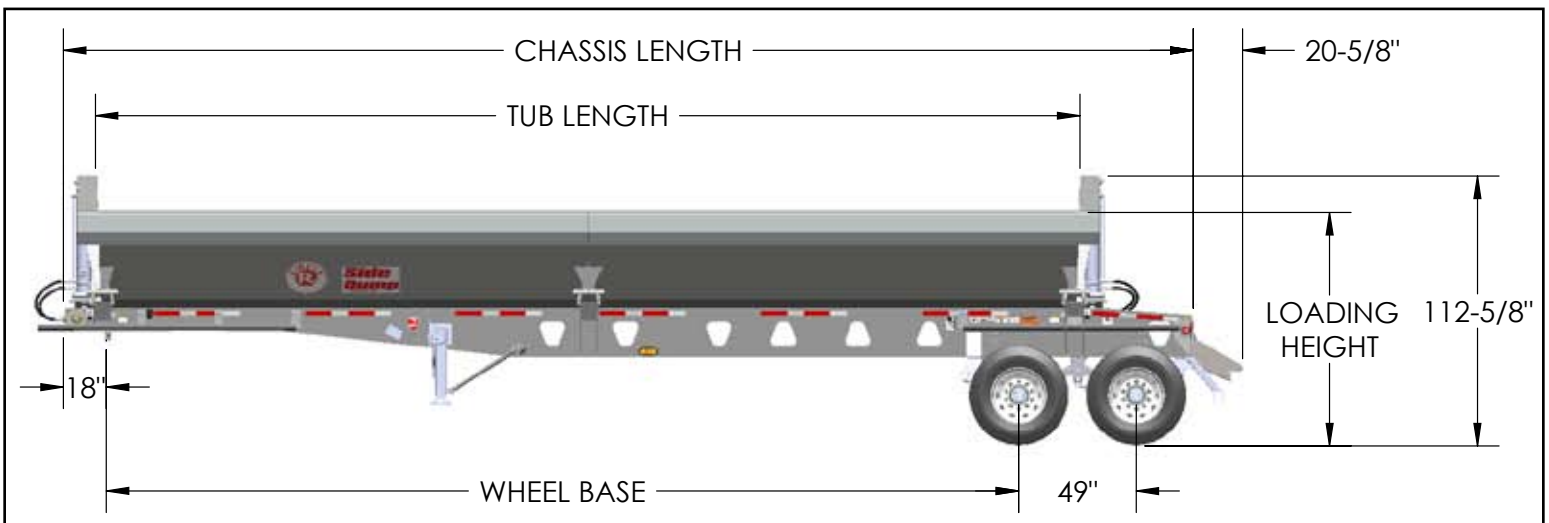
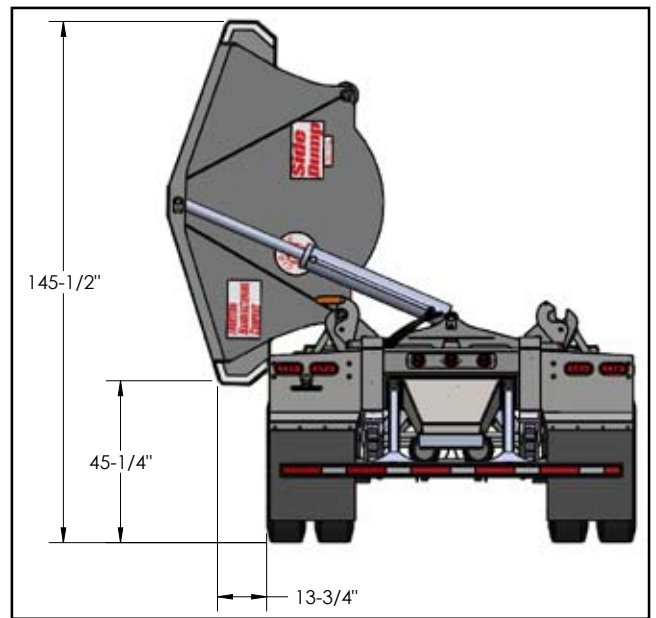

Model	Suspension	Chassis Length	Wheel Base	Tub Length	Tub Volume	Loading Height
35' Tandem	Leaf Spring	35'-4"	333"	30'-3"	21.4 Cu Yd	97'-1/2"
	Air Ride	35'-4"	324.5"	30'-3"	21.4 Cu Yd	97'-1/2"
40' Tandem	Leaf Spring	39'-4"	381"	34'-3"	24.2 Cu Yd	97'-1/2"
	Single Point	39'-4"	380"	34'-3"	24.2 Cu Yd	97'-1/2"
	Air Ride	40'-5"	383"	34'-3"	24.2 Cu Yd	97'-1/2"

NOTE: Heights measured with 11R22.5 tires.